

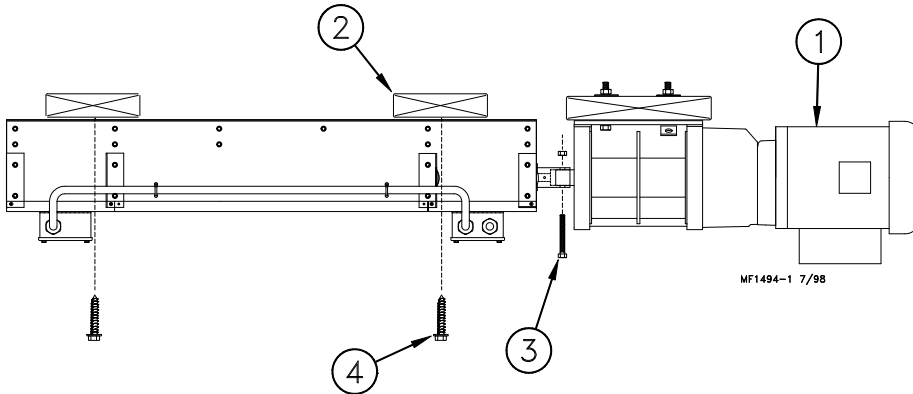

Multi-Lift™ Limit Switch Assembly Part No. 39464

1. Mount winch to the ceiling and hook up the cable.
2. Mount limit switch assembly to ceiling using (4) 1/4" lag screws provided and attach to the output shaft of Multi-Lift™ using the included 5/16-18 x 2.50" bolt and 5/16-18 nut. See Figure 1. Then remove the 5/16-18 nut and 5/16-18 x 2.50" bolt to allow the MULTI-LIFT™ to turn without turning the Limit Switch Assembly.



Key	Description
1	Multi-Lift™ Winch
2	2" X 6" Mounting Board
3	5/16-18 x 2.5" Bolt and 5/16-18 Nut
4	1/4" Lag Screws

Figure 1. Limit Switch Mounting.

3. Wire per wiring diagram.

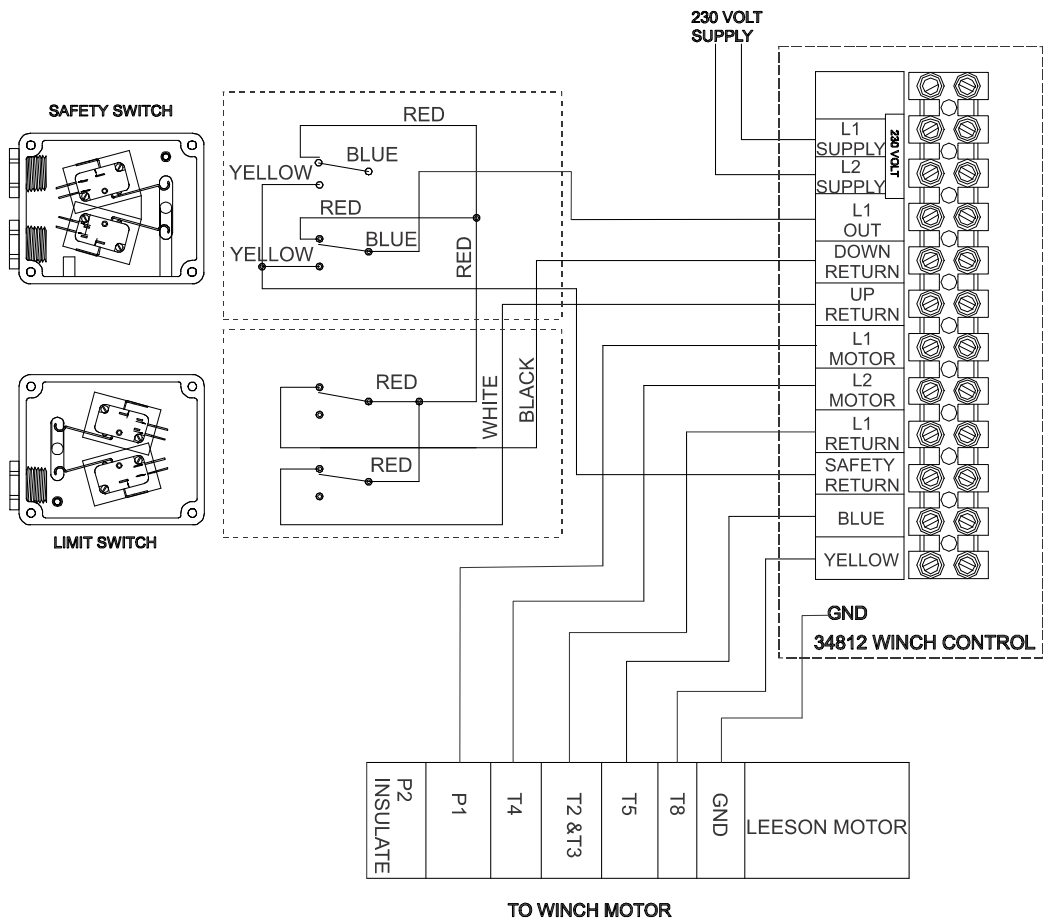
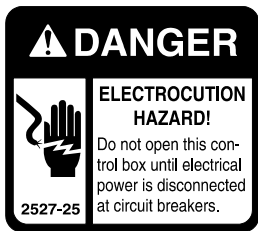

Figure 2. Wiring Diagram.

Setting the up Limit

1. Remove the large center cover.
2. Run the MULTI-LIFT™ to pick up the feeder and raise to within 3” - 4” of its fully raised position. Then re-install the 5/16-18 x 2.50” bolt and the 5/16-18 Nut.

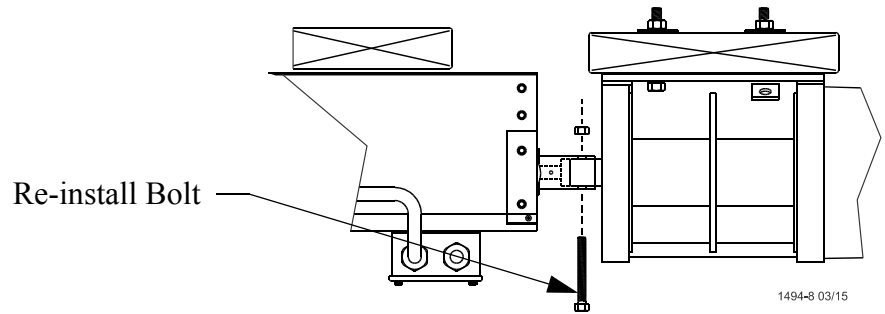
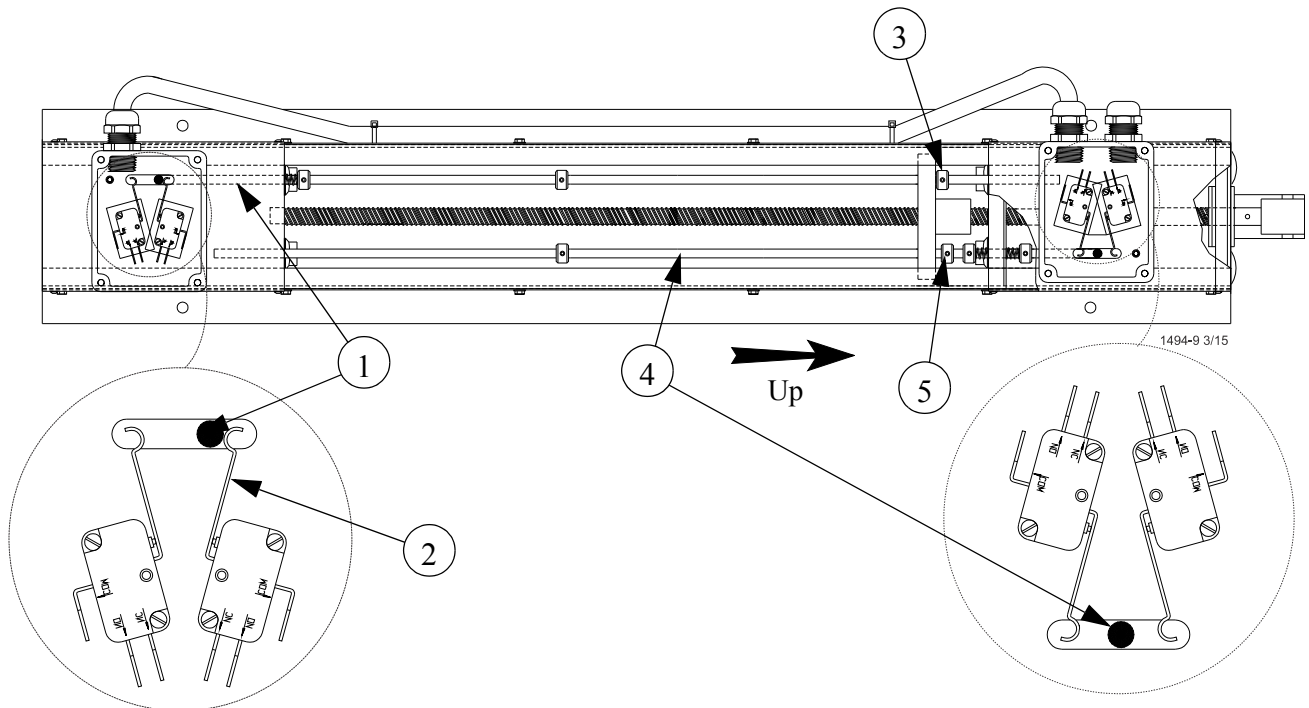

Figure 3. Re-install the connection Bolt

3. Move the Limit Switch Rod (1) until the Limit Switch (2) clicks. Slide Set Collar (3) up against the block and tighten (**Torque to 30 In-Lbs**).
4. Leaving the Safety Switch Rod (4) in a relaxed position, move Set Collar (5) up to the block and tighten. (**Torque to 30 In-Lbs**).



Item	Description
1	Limit Switch Rod
2	Limit Switch
3	"Up" Limit Switch Set Collar
4	Safety Switch Rod
5	"Up" Safety Switch Set Collar

Figure 4. Setting "up" Limit Switches

Setting the down Limit

1. Run the MULTI-LIFT™ down until you have reached the desired Feeder height. It may be necessary to loosen the Set Collars (1 and 2).
2. Move the Switch Rod (3) until the Limit Switch (4) clicks. Hold the Down Limit Switch set collar (1) up against the block and tighten (**Torque to 30 In-Lbs.**).
3. Leaving the safety switch rod (5) in a relaxed position, move set collar (2) up to the block and tighten.
4. Put cover back on.

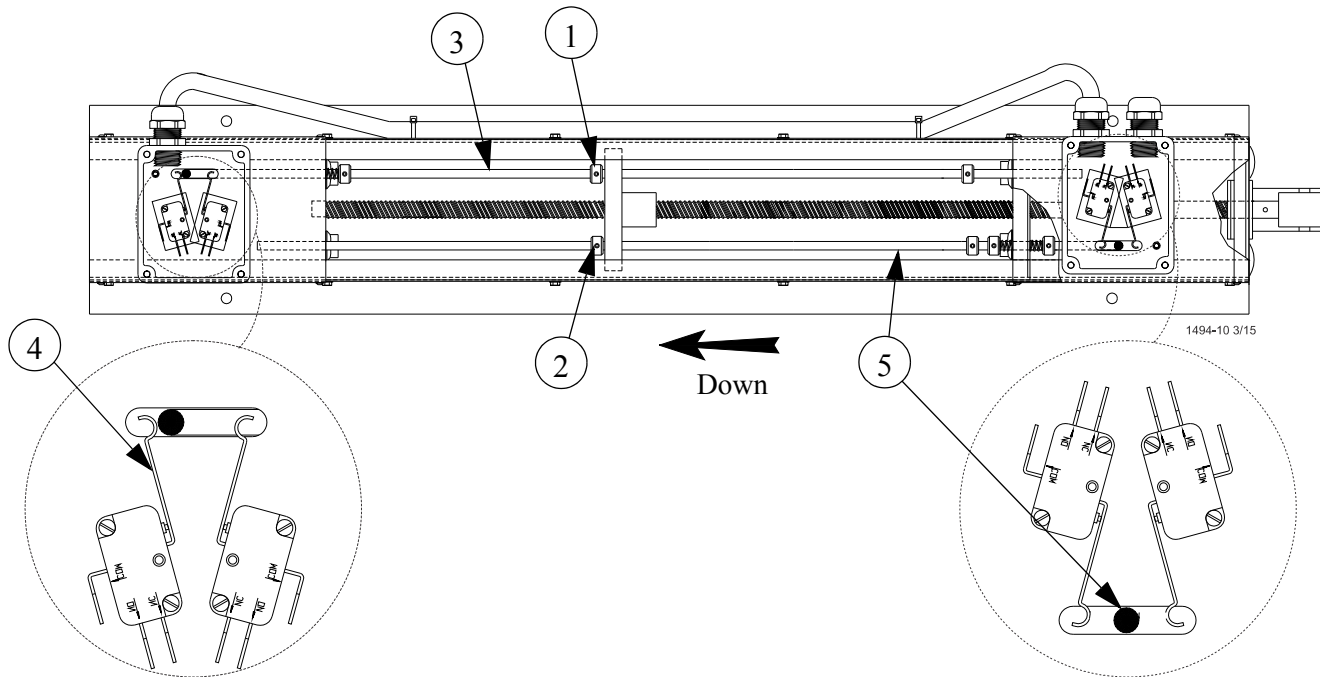

Item	Description
1	"Down" Limit Switch Set Collar
2	"Down" Safety Switch Set Collar
3	Limit Switch Rod
4	Limit Switch
5	Safety Switch Rod

Figure 5. Setting "down" Limit Switches

Parts Listing

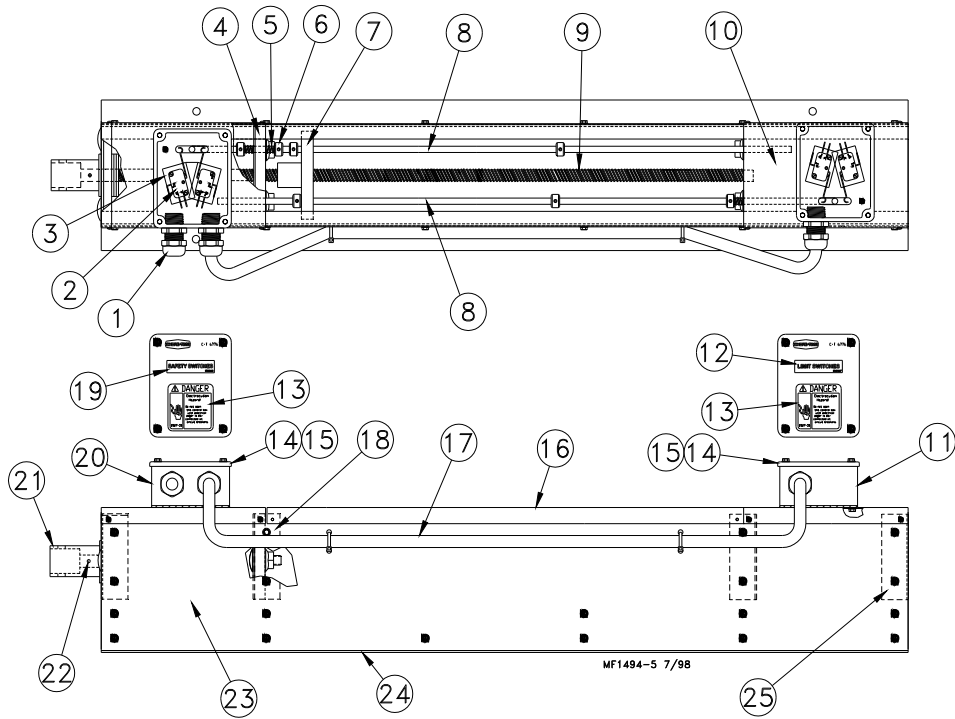

Item	Description	Part No.
1	Liquid Tight Connector	23779
2	Micro Switch	46324
3	Switch Insulation	1907-8
4	Drive Gear Bearing	39463
5	Compression Spring	7132
6	Set Collar	36438
7	Traveling Block	39457
8	Switch Rod	39574
9	Drive Screw	39462
10	Switch Mounting Panel	39458
11	Terminal Box	36334-3
12	Limit Switch Decal	2529-632
13	Danger Decal	2527-35

Item	Description	Part No.
14	Switch Box Cover	6776
15	Gasket	6777
16	Limit Switch Cover	39590
17	Cord Assembly	4999-98
18	Bearing Retainer	39461
19	Safety Switch Decal	2529-631
20	Terminal Box	36334
21	Connector Adaptor	39459
22	Spiral Pin	2960-3
23	Side Panel	39456
24	Base Mount	39455
25	End Panel	39460

Page intentionally left blank.....



**Made to work.
Built to last.®**

Revisions to this Manual

Page No.	Description of Change
Various 4	Clarified setup instructions. Changed 6049 to 46324

Contact your nearby Chore-Time distributor or representative for additional parts and information.

CTB Inc.
P.O. Box 2000 • Milford, Indiana 46542-2000 • U.S.A.
Phone (574) 658-4101 • Fax (877) 730-8825
E-Mail: ctb@ctbinc.com • Internet: <http://www.ctbinc.com>